



New York Yacht Club Vanguard 15 Team Race August, 28-29, 2010

Organizing Authority (OA): New York Yacht Club (NYYC)

SAILING INSTRUCTIONS

1 RULES

- 1.1 The regatta will be governed by the rules as defined in *The Racing Rules of Sailing* (RRS), including Appendix D. The Vanguard 15 class rules apply.
- 1.2 If there is a conflict between the Notice of Race and the Sailing Instructions, the Sailing Instructions shall take precedence.
- 1.3 Appendix S of the RRS will apply, as changed below. See SI 10.
- 1.4 USCG-approved Type III PFDs shall be worn at all times while on the water except while actively adding or removing clothing. Competitors shall supply their own PFDs. PFDs shall be worn outside of all clothing except the supplied team bib.
- 1.5 No boat shall discharge trash of any kind into the water. The penalty, if any, for a breach of this Sailing Instruction, is at the discretion of the Race Committee.
- 1.6 Boats are prohibited from protesting under SI 1.4 and 1.5. This changes rule 60.1(a).

2 NOTICES TO COMPETITORS

Notices to competitors will be posted on the Official Notice Board in the Sailing Center of New York Yacht Club, Harbour Court.

3 CHANGES TO THE SAILING INSTRUCTIONS

Changes to the Sailing Instructions made ashore will be posted soon after the Participants' Meeting on the day it will take effect. Written or oral changes to the Sailing Instructions, including the format, may be made afloat after the display of the flag Third Substitute.

4 SIGNALS MADE ASHORE

When Flag AP (Postponement) is displayed ashore, the warning signal will be made not less than 15 minutes after AP is lowered. This changes Race Signals "AP".

5 SCHEDULE

- 5.1 Participants' Meetings will be held in the Carriage House at 0930 on Saturday, and at 0900 on Sunday. The time of the warning signal for the first race on that date will be announced at the meeting. Competitors should be prepared to go sailing immediately after the meeting.
- 5.2 The Race Committee will endeavor not to begin a new round after 1500 on Sunday. However, weather conditions and/or the progress of the event may govern the actual conclusion of racing.

6 REGATTA FORMAT

- 6.1 A suggested format follows. This is subject to change depending on time and weather conditions.

STAGE 1

- a) Round Robin 1A amongst two groups (A and B) of 10 teams each as divided by the OA;
- b) Round Robin 1B amongst the RED fleet (top five from A and B) and the BLUE fleet (bottom five from A and B) where teams will only race the five teams they have not yet raced. Wins in the RED fleet are worth 2 points.

STAGE 2

Round Robin 2 amongst the GOLD fleet (round-robin with the top 8 teams from RED and top 2 teams from BLUE) and the SILVER fleet (round-robin with the bottom 2 teams from RED and bottom 8 teams from BLUE). Wins in Stage 2 are worth 2 points.

STAGE 3

The OA will announce further rounds as time and weather conditions permit. These may include single or multiple mini-round robins. Wins in Stage 3 are worth 2 points.

- 6.2 The regatta format and number of races will be determined by the Race Committee based on the number of teams and the weather conditions. The Race Committee may skip an earlier round in favor of a later round.
- 6.3 The regatta format may be changed on the water; see SI 3. The Race Committee will display flags to indicate the Round Robin currently being sailed (e.g. numeral pennant '1' over 'A', etc.)
- 6.4 If time, wind, weather or other contingencies make the completion of a current or an additional scheduled round robin or series impractical, the regatta may be terminated and the results based on the standings at the completion of the immediate prior round robin(s) or series. Alternatively, the Organizing Authority may terminate or alter the format in progress, or make such other arrangements as may be necessary to conclude the event.

7 RACING AREA

The racing area will be announced at the Participants' Meeting.

8 COURSE & MARKS

- 8.1 The course will be a "digital N" as shown.
- 8.2 The Race Committee may change a leg of the course that begins at a rounding mark by changing the position of the next mark or the finishing line, but no mark shall be moved when any boat is on the leg that it terminates. Subsequent legs may be changed to maintain the course configuration. There will be no visual or audible signals for a course change. This changes rule 33.
- 8.3 Rounding marks will be round orange inflatable buoys. The starting and finishing marks will be round yellow inflatable buoys.
- 8.4 Courses will not be shortened. This changes rule 32 and Race Signals "S".

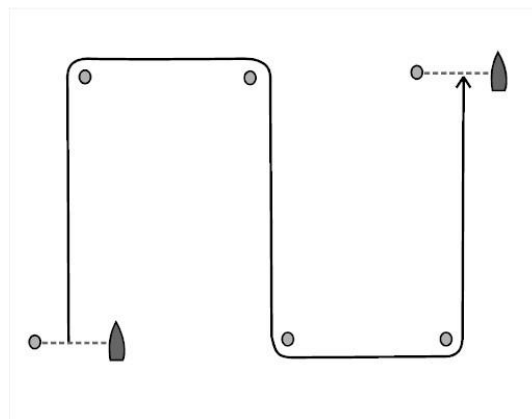

9 SCORING

Scoring will be in accordance with Appendix D.

10 THE START AND ORDER OF RACES

- 10.1 Races will be run in accordance with the rotation distributed at the Participants' Meeting or as designated by the Race Committee in accordance with SI 3.
- 10.2 Team numbers for upcoming races will be displayed on the Race Committee boat as described at the Participants' Meeting.
- 10.3 The starting line will be between the staff displaying an orange flag on the Starting Race Committee boat and the course side of the nearby mark. The signal boat may deploy a "keep off" buoy from her stern. This buoy and the line attaching it to the signal boat shall be considered an integral part of the signal boat.
- 10.4 The starting sequence in rule S3 will be used (Sound-Signal Starting System) and changed as follows:

<i>Signal</i>	<i>Sound</i>	<i>Time before Start</i>
Warning	2 long	2 minutes
Preparatory	1 long, 3 short	1 minute, 30 seconds
	1 long	1 minute

etc.

- 10.5 The starting signal for one race will be the warning signal for the next race, unless there is a postponement, abandonment or a general recall. The starting sequence may be paused without postponing to allow the race committee flexibility in managing the races.

- 10.6 A boat starting more than two minutes after her starting signal will be scored “DNS” without a hearing. This changes rules 63.1 and D3.1.
- 10.7 If flag “X” is displayed, it will remain displayed until all OCS boats are completely on the pre-course side of the starting line or its extensions, or for one minute, whichever occurs first.
- 11 THE FINISH**
The finishing line will be between a staff displaying an orange flag on Finish Race Committee boat and the course side of the nearby mark.
- 12 TIME LIMIT**
There will be no time limit for any race.
- 13 PROTESTS**
- 13.1 Rule D2.4(b) applies to all protests.
- 13.2 The Race Committee may require protests to be heard on the water directly after the parties involved have finished the race. The “three-minute justice” system will be used, which changes rule 63.2 regarding time for preparation for the hearing, and rule 63.6 regarding the calling of witnesses. The Protest Committee will consist of competitors on teams that are not involved in the protest, per customary application of the “three-minute justice” system, unless the Race Committee determines that it is more efficient to have members of the Race Committee constitute the Protest Committee.
- 14 NOTES**
- 14.1 Competitors are reminded that Narragansett Bay is a restricted channel and sailing vessels do not have the right of way over a vessel under power that may be restricted in its ability to maneuver. Boats that infringe the Preamble of Part 2 of the rules may be protested only by the Race Committee. This changes rule 60.1(a).
- 14.2 All times herein are Eastern Daylight Time.
- 14.3 Tides:
- | | <u>High</u> | <u>Low</u> |
|---------------------|-------------|------------|
| Saturday, August 28 | 1035 | 1618 |
| Sunday, August 29 | 1112 | 1654 |
- 15 SAFETY**
In accordance with rule 4, the responsibility for a boat’s decision to participate in a race or to continue racing is hers alone. The responsibility for the safety of the boat and each competitor lies solely with each individual and not with the Organizing Authority, the New York Yacht Club, or any of their respective representatives.
- 16 PRIZES**
Prizes will be awarded to the top three teams.
- 17 OTHER**
- 17.1 Government buoys have no required side except for safe navigation.
- 17.2 The legal drinking age in the State of Rhode Island is 21. Violations of this law will not be tolerated and will be communicated to the appropriate authorities.

ORGANIZING COMMITTEE

Rob Richards – Event Chair
Joseph Aleardi, Benjamin Kinney – Team Racing co-Captains
Colin Gordon, Chris Woods – Co-Chair, NYYC Team Racing Sub-Committee
A. Rives Potts, Jr. – Chair, NYYC Sailing Committee
David K. Elwell, Jr. – Commodore
Beth Duggan – Racing Coordinator

RACE COMMITTEE

Rob Richards - PRO
A.J. Evans – APRO
Senet Bischoff
Daniela Burton
Tom Duggan
Martha Carleton Glenn
Ned Glenn
Sarah Gochberg
Ronald A. Hopkins
David Morse
Heather Tow-Yick
Robin Wallace