



# NYYC RACE WEEK AT NEWPORT

## *Presented by ROLEX*

Classics Regatta and Olin J. Stephens 100<sup>th</sup> Birthday Celebration

New York Yacht Club, Harbour Court, Newport, Rhode Island  
*July 18-20, 2008*

### SAILING INSTRUCTIONS

#### 1 RULES

- 1.1 The regatta will be governed by the rules as defined in *The Racing Rules of Sailing* (RRS).
- 1.2 **Regatta Regulations:** The Regatta Regulations will apply and are included in Appendix 3, as well as posted on the Race Week website at [http://nyyc.org/yachtracing/event\\_191](http://nyyc.org/yachtracing/event_191).
- 1.3 **Check-in:** Each yacht shall register at the check-in desk at the NYYC Sailing Center at Harbour Court prior to racing at the times so designated in the notice of race.
- 1.4 **Crew Waiver:** No crew shall be aboard a yacht while racing unless he/she has executed a Crew Waiver Form. The Crew Waiver Forms are available on the Race Week website and will be available at check-in. Registration will not be complete without receipt of a complete Crew Waiver Form.
- 1.5 **Offshore Special Regulations:** Minimally all yachts shall comply with the 2008-2009 ISAF Offshore Special Regulations, Category 5 (posted on the Race Week website) and shall comply with their class rules, where applicable. Yachts that are not normally rigged with lifelines are exempt from Regulation 3.14. In the event of a conflict between these regulations and applicable class rules, the class rules shall apply. The US SAILING prescriptions to the Offshore Special Regulations shall apply except the requirement to wear personal flotation while starting and finishing.
- 1.6 The Protest Committee may impose suitable penalties, other than disqualification, for violations of the ISAF Offshore Special Regulations or other non-Part 2 rules. This changes RRS 64.1.
- 1.7 The 2008 PHRF-NB Regulations shall apply to yachts racing under PHRF.
- 1.8 The current relevant class rules shall apply to all yachts racing as a one-design class.
- 1.9 For CRF classes only:

In accordance with the US SAILING prescription to rule 86.3, the following rules will be tested for this regatta.

**For the purposes of rules 10, 13, 14, 15 and 16, the definition of *keep clear* is changed to:**

**Keep Clear:** One boat keeps clear of another when she is more than one of her hull lengths away from the other boat, the other can sail her course with no need to take avoiding action and, when the boats are overlapped on the same tack and the leeward boat can change course in both directions without immediately making contact with the windward boat.

#### 2 ENTRIES

Eligible yachts shall enter by completing on-line registration with the Organizing Authority. Eligibility requirements for yachts and method of entry are detailed in the Notice of Race.

### **3 NOTICES, COMPETITOR INFORMATION AND SIGNALS MADE ASHORE**

- 3.1 Notices, including race results, amendments and protest hearing schedules, will be posted on the Official Notice Board located in the courtyard of the NYYC Sailing Center at Harbour Court. This information will also be posted on the Race Week website.
- 3.2 Flag signals will be flown from the western side of the yardarm of the flagpole at Harbour Court.
- 3.3 Any change to the sailing instructions will be posted before 0900 on the day it will take effect, except that any change to the schedule of races will be posted by 2000 on the day before it will take effect. Flag “Lima” will be flown to signify such posting.
- 3.4 When Pennant “AP” is displayed ashore, “one minute” is replaced with “not less than one hour” in Race Signal “AP”.
- 3.5 Signals designating the rendezvous locations will be displayed at 0900 each day on the western side of the yardarm at Harbour Court. The Race Committee will endeavor to announce the locations as described in Appendix 2 – Rendezvous Locations at that time over VHF Channel 72. The failure to make this announcement or for a yacht to hear this announcement will not be grounds for redress. This changes rule 62.1(a).
- 3.6 After the rendezvous locations and any other regatta announcements have been made, Race Committee Signal Boats will monitor and communicate with their respective fleets on the VHF channels published on the scratch sheet.

### **4 CLASSES AND IDENTIFICATION**

- 4.1 The Organizing Authority will divide yachts into classes. Classes will be assigned a numeral designation and placed into a default fleet. A class’ fleet assignment may change on a given day due to the racing schedule, and if so, will be announced at 0900 during the morning announcements.
- 4.2 Each fleet will have a designated racing circle and VHF channel as described on the scratch sheet.
- 4.3 The scratch sheets will be distributed at check-in, posted on the Official Notice Board and posted on the Race Week website.
- 4.4 Each yacht shall display the numeral pennant corresponding to her class designation from her backstay, approximately six feet above the deck, from the warning signal of the first class in her fleet until she is no longer racing.
- 4.5 Each yacht shall display the sponsor flag provided from her backstay below her class numeral pennant.

### **5 SCHEDULE OF RACES**

- 5.1 Racing for the 12 Metre classes will be held on Friday, July 18 through Sunday, July 20. Racing for the Classics, S&S class, 6 Metres and Herreshoff ‘S’ Class will be held on Saturday, July 19 and Sunday, July 20. Racing for the Shields class will be held on Saturday, July 19.
- 5.2 The scheduled time for the course signals is 1055 and the warning signal is 1100 for the first race each day. For subsequent races, the course signals will be made five minutes prior to the warning signal.
- 5.3 No warning signal shall be made after 1500 on Sunday, July 20.

### **6 RENDEZVOUS LOCATIONS**

Fleet rendezvous locations are as described in Appendix 2 – Rendezvous Locations and will be designated as described in SI 3.5.

### **7 CHECK-IN AND RETIREMENT**

- 7.1 Prior to the warning signal for the first race each day, all yachts shall check-in with the Race Committee Signal Boat by passing astern on Starboard Tack and announcing their sail number. The Race Committee will acknowledge by responding with the number heard.
- 7.2 Yachts retiring are requested to inform the Race Committee on their Fleet VHF channel or by calling (401) 845-9633.

### **8 THE COURSES**

- 8.1 Courses will be either: Drop Mark courses, an Around-the-Island course or Special courses using buoys as designated on the 2005-2008 South Bay Race Chart provided at registration. The Shields Class should refer to Appendix 5 – Shields Courses.

8.2 The course designation will be signaled using letter flags as described below and will be displayed on a pole flown forward on the Race Committee Signal Boat.

8.3 **Drop Mark Course Diagrams** - See Appendix 1 - Course Card.

- a) Course “W” is a Windward/Leeward course with a windward offset mark. A numeral pennant indicating the number of LEGS to be raced will be flown beneath Flag “W”. The distance between the windward mark and the offset mark shall not count as a leg for the purposes of indicating the number of legs.
- b) Course “O” is a Triangle/Windward/Leeward/Windward course.
- c) Course “K” is a Triangle/Windward/Leeward course.
- d) The leeward mark for Courses “W”, “O”, and “K” will be an inflatable mark(s) set approximately 0.10 NM to windward of the starting line. When there is a gate, yachts shall sail between the gate marks from the direction of the previous mark and round either gate mark. There will be a windward offset mark adjacent to the windward mark for all drop mark courses.
- e) The distance and bearing to the first mark will be signaled using numeral pennants displayed on poles. The course designation will be flown forward, followed by the three pennants designating the magnetic bearing to the first mark, followed by the two pennants designating distance (nautical miles and tenths) to the first mark.
- f) Marks, including the windward offset mark, shall be rounded in order and left to port, except that a gate, when used, shall be rounded as described in SI 8.3(d).

8.4 **Around-the-Island Courses** – see Appendix 4.

8.5 **Special Courses using the 2005-2008 South Bay Race Chart** will be designated by flag “D”.

- a) When flag “D” is displayed, the Race Committee will list the marks on a white board in the order to be rounded using the designations on the 2005-2008 South Bay Race Chart provided at registration.
- b) Special Mark “U”
  - The Race Committee may add an inflatable first mark to any course by displaying flag “U” below flag “D”. If “U” is used, there will be either a Green or Red flag displayed below “U” to designate the direction to be rounded.
  - Mark “U” is to be rounded either to STARBOARD (Green flag below “U”), or to PORT (Red flag below “U”).
  - The bearing and distance to Mark “U” will be displayed as described in SI 8.3(e).
  - Mark “U” will be an 8’ YELLOW tetrahedron buoy.
- c) The course will be:
  - Start
  - Special Mark “U” if used
  - Round the marks in the designated order leaving each mark to port or starboard such that the rhumbline to any mark does not cross the rhumbline from that mark to the next mark. If the next leg is a reciprocal (i.e. returning to the same mark), leave the rounding mark to port.
  - Finish
- d) The finishing mark will be on the opposite side of the Race Committee Signal Boat from the starting mark.

## 9 MARKS

9.1 Rounding marks for Drop Mark Courses and Mark “U” will be 8’ YELLOW inflatable tetrahedron buoys. Starting and finishing marks will be 5’ ORANGE inflatable tetrahedron buoys.

9.2 Offset marks will be small cylindrical orange inflatable buoys.

9.3 A new mark, as provided in SI 12, will be an 8’ ORANGE inflatable tetrahedron. For a subsequent change, the new mark will be the same as the original mark.

## **10 THE START**

- 10.1 Races will be started in accordance with rule 26, with classes starting at “5-minute” intervals.
- 10.2 A yacht starting later than 20 minutes after her starting signal will be scored Did Not Start. This changes rule A4.
- 10.3 The starting line will be between a staff displaying an orange flag on the Race Committee Signal Boat and the course side of the port-end starting mark. The Race Committee may deploy astern a “Keep Off” buoy that shall be considered an integral part of the Race Committee Signal Boat.
- 10.4 Yachts whose warning signal has not been made shall keep clear of the starting area.
- 10.5 Sample sequence:
- |      |   |
|------|---|
| 1055 | Course Signals                                  |
| 1100 | Warning for first class                         |
| 1101 | Preparatory for first class                     |
| 1105 | Start for first class, Warning for second class |
| 1106 | Preparatory for second class                    |
| 1110 | Start for second class, Warning for third class |
| 1111 | Preparatory for third class                     |
| 1115 | Start for third class, etc.                     |

## **11 INDIVIDUAL RECALLS**

The Race Committee will endeavor to hail each premature starter over their respective fleet VHF channel. Failure to make such an announcement shall not be grounds for redress. This changes rule 62.1(a).

## **12 COURSE CHANGE**

In addition to the requirements in rule 33, the Race Committee will attempt to announce any course change on their respective fleet VHF channel. Failure to make such an announcement shall not be grounds for redress. This changes rule 62.1(a).

## **13 THE FINISH**

- 13.1 The finishing line will be between a staff displaying an orange flag on a Race Committee Boat and the finishing mark.
- (a) For Course “W”, with an odd number of legs, and Course “O”, the finish line will be located approximately 0.1 NM to windward of the windward mark.
  - (b) For Course “W”, with an even number of legs, and Course “K”, the finish line will be located approximately 0.1 NM to leeward of the leeward mark(s) and the finishing mark will be on the opposite side of the Race Committee Signal Boat from the starting mark. See diagrams in Appendix 1 - Course Card.
  - (c) For Course “D”, the finishing mark will be on the opposite side of the Race Committee Signal Boat from the starting mark.
- 13.2 The finishing line for the Around-the-Island Race Courses will be between a staff displaying an orange flag on a Race Committee Boat and the finishing mark which will be an 8’ inflatable orange tetrahedron buoy. The finishing line will be located approximately 0.25 NM north of the Fl R 6 sec Horn “2” on the northern point of Fort Adams.
- 13.3 If a subsequent race is to be sailed, the finish line Race Committee Boat will fly Pennant “Second Substitute” with the Blue On-Station Signal at the finish. If a Class Flag is displayed below Pennant “Second Substitute” the subsequent race is for that division(s) only.
- 13.4 In fog at the finish, the Race Committee Boat may ring a bell rapidly, for approximately 5 seconds, at intervals. The same Race Committee Boat may or may not start and finish each race.

## **14 PENALTY SYSTEM**

- 14.1 A yacht that may have broken a rule of Part 2 while racing may take a penalty at the time of the incident either:
- (a) as provided in her class rules, or if the class rules do not specify,
  - (b) by taking a Two-Turns Penalty in accordance with rule 44.2, or

(c) by taking a Scoring Penalty in accordance with rule 44.3.

This changes rule 44.1.

14.2 If rule 44.3, Scoring Penalty, is elected, the infringing yacht shall file a penalty flag acceptance form with the Jury Secretary at the Sailing Center in addition to other requirements of rule 44.3. The penalty flag acceptance form must be filed within one hour after the Race Committee Signal Boat has docked. This changes rule 44.3(a).

14.3 A yacht that accepts a Scoring Penalty shall receive additional points equal to 20% of the entrants in that race (rounding 0.5 upward), but shall not have less than two places added to her actual finish position. This changes rule 44.3 (c).

## **15 TIME LIMIT**

15.1 The time limit for the first yacht to sail the course and finish is as follows:

(a) For a drop mark course, the time limit will be three hours.

(b) For Special Course 'D' using the South Bay Race Chart, the time limit will be four hours.

(c) For the Around-the-Island Race courses, the time limit will be five hours.

15.2 Yachts failing to finish within 30 minutes (plus their handicap allowance, if applicable) of the first yacht to sail the course and finish, or within the time limit, whichever is later, will be scored Did Not Finish (DNF) and scored points as described in SI 17.3. This changes rules 35 and A4.

## **16 PROTESTS AND REQUESTS FOR REDRESS**

16.1 Intention to protest and the yacht being protested shall be signified to the Race Committee on the fleet VHF channel at the finish of a race until acknowledged by the Race Committee. This changes rule 61.1(a).

16.2 Written protests or requests for redress shall be submitted to the Jury secretary in the NYYC Sailing Center as soon as possible, but not later than one hour after the Race Committee Signal Boat for that fleet has docked. The time limit for filing a protest will be posted on the Official Notice Board.

16.3 Protest notices will be posted as soon as possible on the Official Notice Board.

16.4 Protest hearings will take place at the NYYC Sailing Center as soon as possible after the notices are posted. The Jury will attempt to hear protests in the order of receipt. Representatives of yachts who are parties to a hearing shall remain on call in the vicinity of the protest rooms.

16.5 When a yacht has been involved in an incident that may be subject to protest, it is her responsibility to check the protest notices at the end of the protest filing time to see if she is cited in a protest. Failure of any yacht to appear when called for a hearing will be considered by the Jury as grounds for proceeding under rule 63.3(b).

16.6 Rule 63.5 is changed by adding, "A protest involving contact may be heard by the Protest Committee even though the requirements of rule 61.1(a) and 61.3 have not been fulfilled."

16.7 Breaches of sailing instructions 4.4, 4.5, 7, 10.4, 14.2, and 19.2 will not be grounds for a protest by a yacht. This changes rule 60.1(a).

16.8 A violation of SI 19.2 will be considered "a gross breach of a *rule*" under rule 69.1(a) and may result in the yacht being scored DNE (Disqualification not excludable).

## **17 SCORING**

17.1 A yacht's series score will be the total of her race scores without discard. This changes rule A2.

17.2 One race is required to be completed to constitute a series.

17.3 Yachts that have started and fail to finish within the time limit for any reason, shall, without a hearing, be scored by the Race Committee with points equal to the number of yachts in her class that have sailed the course and finished within the time limit, plus two. This changes rule A4.1, A4.2, and A5.

## **18 PRIZES**

18.1 Prizes for the winner of each race will be presented at the Awards Party after each day of racing.

18.2 Overall prizes will be awarded to the winning yacht in each class. Second place prizes will be awarded for classes with five or more yachts; and third place if eight or more.

18.3 Classes holding a class championship may present special class trophies.

18.4 Class prizes will be awarded at the Rolex Awards on Sunday, July 20.

## 19 NOTES

19.1 Competitors are reminded that Narragansett Bay and its approaches are considered restricted channels for commercial traffic and vessels in the navigation channel restricted in their ability to maneuver. Competitors must comply with the government right-of-way rules when in proximity to commercial or privileged marine traffic. A violation of this sailing instruction shall be considered a breach of the Preamble to Part 2 and may be considered a breach of RRS 2. Upon observation or receipt of any report of an incident, the Race Committee or Protest Committee shall protest a yacht. This changes rule 60.2(a) and 60.3(a).

19.2 In the event there is racing in Narragansett Bay, competitors should be aware of heightened security around the Navy base in Newport just to the north of the Newport Jamestown Bridge. The area to the east of a line defined by a series of white buoys marking the Newport Security Zone along the coast of the Naval Facilities from Coasters Harbor to the breakwater at the north end of Coddington Cove shall rank as an obstruction. Yachts shall not enter this area. A Navy patrol boat monitors the area and vessels navigating in the Exclusionary Zone may face action by Coast Guard and Naval authorities.

19.3 Newport Tides

Day	Date	High Tide	Low Tide
Friday	July 18	0834	1358
Saturday	July 19	0913	1441
Sunday	July 20	0952	1523

19.4 All times herein are Eastern Daylight times. Bearings are in degrees magnetic and are approximate. Distances used herein are expressed in nautical miles (when not otherwise defined) and are approximate.

19.5 For further information please contact: New York Yacht Club, Harbour Court  
5 Halidon Avenue; Newport, RI 02840  
Tel: 401/845-9633, Fax: 401/846-3303  
Website: [www.nyyc.org](http://www.nyyc.org)  
email: [sailingoffice@nyyc.org](mailto:sailingoffice@nyyc.org)

## NEW YORK YACHT CLUB RACE WEEK AT NEWPORT

Presented by



## **RACE COMMITTEE**

John. L. Myles, Jr., Chairman

Richard V. Thursby, Principal Race Officer

Thomas F. Delaney, Assistant PRO

Samuel W. Wakeman, Principal Race Officer

Elizabeth Isdale Cochran, Assistant PRO

Robert Armes

Richard Chesebrough, LCDR, USN (Ret)

Dorothea Chesebrough

Elizabeth Condon

John I. Condon, Jr.

James F. Crowley

Linda Delaney

Jerry J. Fand

Ingrid M. Flynn

Thomas K. Flynn

Richard R. Gumpert

Henry Howard, II

Barbara Dixon Jackson

Daniel Jackson

Timothy M. James

David M. Morse

Dorothy B. Myles

John D. Osmond, III, MD

Ellyn Coyle Osmond

## **PROTEST COMMITTEE**

Robert B. Conner, Chairman

Carol Barrow

LCDR Richard Chesebrough, USN (Ret)

Daniel A. Davis

Noel M. Field, Jr.

Richard R. Gumpert

Stephen B. Jeffries

Timothea Larr

John D. Osmond, III, MD

Arthur Wullschleger

Betty Smith, Jury Secretary

Cathy Kennedy, Jury Secretary



## APPENDIX 1 – DROP MARK COURSE CARD

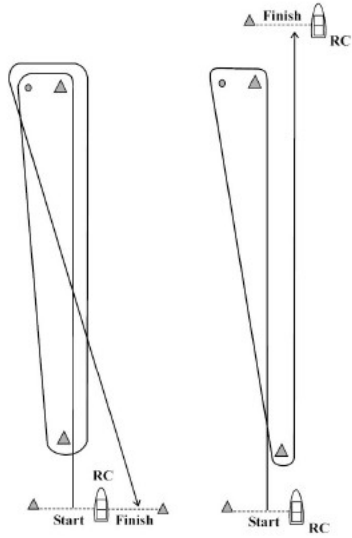

**Course "W"**  
Even # legs

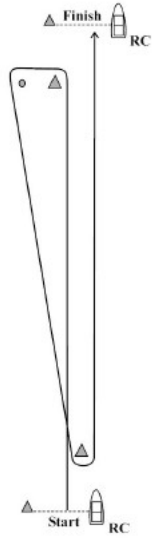

**Course "W"**  
Odd # legs

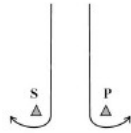

**Gate Marks**

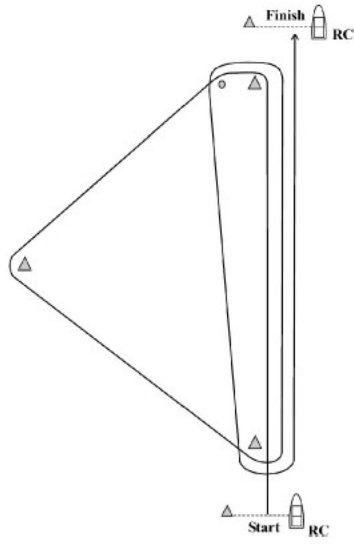

**Course "O"**

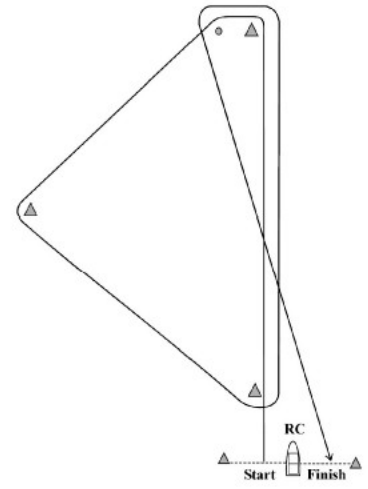

**Course "K"**



## APPENDIX 2 - RENDEZVOUS LOCATIONS

### **Rhode Island Sound:**

- Area “A” - in the vicinity of 160° for 1.2 NM from R “2” QR Whistle marking Brenton Point
- Area “B” - in the vicinity of 120° for 2.5 NM from R “2” QR Whistle marking Brenton Point
- Area “C” - in the vicinity of 225° for 2.0 NM from R “2” QR Whistle marking Brenton Point
- Area “D” - in the vicinity of 200° for 3.5 NM from R “2” QR Whistle marking Brenton Point
- Area “E” - in the vicinity of 165° for 2.5 NM from R “2” QR Whistle marking Brenton Point
- Area “F” - in the vicinity of 150° for 4.5 NM from R “2” QR Whistle marking Brenton Point

### **Newport Harbor and near Newport Bridge:**

- Area “J” - in the vicinity of Mackerel Cove (Conanicut Island opposite Castle Hill)
- Area “K” - between Goat Island and Rose Island
- Area “M” - in the vicinity of R “12” west of Rose Island
- Area “N” - off Coasters Harbor Island (just north of east end of Newport Bridge)
- Area “O” - in the vicinity of Potter Cove (just north of west end of Newport Bridge)

### **North of Newport Bridge:**

- Area “R” - in the vicinity of 200° for 0.5 NM from Halfway Rock
- Area “S” - in the vicinity of RG Nun south of Prudence Island
- Area “T” - in the vicinity of G “7” QG off Quonset Point
- Area “U” - in the vicinity of C “1” northeast of Hope Island.
- Area “V” - in the vicinity of C “5” 290° for 1.0 NM from Pine Hill Point on Prudence Island
- Area “W” - in the vicinity of G “1” 0.9 NM southwest of Hog Island

## **APPENDIX 3 - REGATTA REGULATIONS**

### **1 REQUIRED EQUIPMENT**

Each yacht shall carry a VHF radio capable of communicating with the race committee on the fleet channels.

### **2 MINIMUM CREW**

The minimum crew aboard while racing shall be three.

### **3 CREW CHANGES**

Yachts shall sail with the same crew in all races, unless (i) permitted by applicable class rules, or (ii) a written request for crew change has been approved in advance by the OA. Any new crew must submit their crew waiver found at [www.nyyc.org](http://www.nyyc.org) to the regatta desk in person or by fax at (401) 846-3303 prior to racing.

### **4 CREW WEIGH-INS**

4.1 Crew weigh-ins will be conducted only if (i) required by a specific class or their class rules, or (ii) a yacht has been protested for violation of the applicable crew weight limitation.

4.2 The official scale will be available at times posted on the Official Notice Board for yachts wishing to confirm their compliance with applicable crew weight limitations.

### **5 CRF REGULATIONS**

Classic yachts shall declare at registration whether they will race using their spinnaker or non-spinnaker CRF rating.

### **6 PHRF REGULATIONS**

#### **6.1 Maximum Crew Weight and Crew Limitations**

<u>Up to LOA (ft)</u>	<u>Weight Limit (lbs)</u>	<u>Max. Crew</u>
25.00	900	5
27.50	1080	6
30.00	1260	7
32.50	1440	8
35.00	1620	9
37.50	1800	10
40.00	1980	11
42.50	2160	12
45.00	2340	13
50.00	2520	14
55.00	2700	15
60.00	2880	16
65.00	3060	17
70.00	3240	18
Over 70.00	3420	19

6.2 PHRF entrants shall present a PHRF handicap certificate issued by PHRF Narragansett Bay. Applications and certificates may be obtained from PHRF-NB by contacting them via:

Website: [www.phrf-nb.org](http://www.phrf-nb.org)

Email: [PHRFAdmin@phrf-nb.org](mailto:PHRFAdmin@phrf-nb.org)

Phone: (401) 253-0207 (Voice); (401) 369-9319 (Fax)

Address: PHRF-NB; P.O. Box 356; Washington, NC 27889

## **APPENDIX 4 – AROUND-THE-ISLAND COURSES**

### **1 COURSES FOR AROUND-THE-ISLAND RACES**

- 1.1 The Race Committee will announce their intention to sail an Around-the-Island race during the morning announcements at 0900 on VHF channel 72 and will announce the rendezvous location, classes affected and intended starting order.
- 1.2 The scheduled time for the course signals is 1055 and the warning signal is 1100 for the first class. The Race Committee will endeavor to announce the designated courses over VHF channel 72. Failure to make such an announcement shall not be grounds for redress. This changes rule 62.1(a).
- 1.3 Special Mark “U”
- The Race Committee may add a new first mark to any course by displaying flag “U” above a Green or Red flag on a separate pole.
  - Mark “U” is to be rounded either to STARBOARD (Green flag below “U”), or to PORT (Red flag below “U”).
  - The bearing and distance to Mark “U” will be displayed as described in SI 8.3(e).
  - Mark “U” will be an 8’ ORANGE tetrahedron buoy.
- 1.4 **Course “J”**, clockwise around Conanicut Island:
- Pass to the east of G “11” and G “9” off the Dumplings
  - RG “NR” Bell 650 yards SW of Beavertail Point to starboard
  - Pass to the west of Dutch Island in the West Passage
  - The center span of the Jamestown Verrazano Bridge
  - C “5” 1250 yards NW of Conanicut Point to starboard
  - R “2” FI R 4 Sec Bell 900 yards NE of Conanicut Point to starboard
  - The center span of the Newport Jamestown Bridge
  - Pass to the west of R “12” off Rose Island
  - Finish off Fort Adams (see SI 13.2)
- 1.5 **Course “JR”** - if Flag “R” is flown beneath Flag “J”, the Around Conanicut Island race shall be sailed in the reverse direction (counter-clockwise), with the above rounding marks passed to port, finishing off Fort Adams.
- 1.6 **Course “G”** – clockwise around Prudence Island
- The center span of the Newport Bridge (only if starting south of the Bridge)
  - R “8” FI R 4 sec W of Northwest Point on Patience Island to starboard
  - RG N 1100 yards N of Providence Point on Prudence Island to starboard
  - G “1” FI G 2.5 sec 0.9 NM SW of Hog Island to starboard
  - Gate between G “25” and R “26” south of Sandy Pt on Prudence Island
  - The center span of the Newport Bridge
  - Pass to the west of R “12” off Rose Island
  - Finish off Fort Adams (see SI 13.2)
- 1.7 **Course “GR”** – if Flag “R” is flown beneath Flag “G”, the Around Prudence Island Race shall be sailed in the reverse direction (counter-clockwise), with the above rounding marks passed to port, finishing off Fort Adams, except that the gate between G “25” and R “26” is not a mark of the course.
- Start
  - Pass to the west of R “12” off Rose Island (only if starting south of the Bridge)
  - The center span of the Newport Bridge (only if starting south of the Bridge)
  - G “1” FI G 2.5 sec 0.9 NM SW of Hog Island to port
  - RG N 1100 yards N of Providence Point on Prudence Island to port
  - R “8” FI R 4 sec W of Northwest Point on Patience Island to port
  - The center span of the Newport Bridge
  - Pass to the west of R “12” off Rose Island
  - Finish off Fort Adams (see SI 13.2)

1.8 **Course “JG”** – clockwise around Conanicut and Prudence Islands

- Pass to the east of G “11” and G “9” off the Dumplings
- RG “NR” Bell 650 yards SW of Beavertail Point to starboard
- Pass to the west of Dutch Island in the West Passage
- The center span of the Jamestown Verrazano Bridge
- R “8” Fl R 4 sec W of Northwest Point on Patience Island to starboard
- RG N 1100 yards N of Providence Point on Prudence Island to starboard
- G “1” Fl G 2.5 sec 0.9 NM SW of Hog Island to starboard
- Gate between G “25” and R “26” south of Sandy Pt on Prudence Island
- The center span of the Newport Bridge
- Pass to the west of R “12” off Rose Island
- Finish off Fort Adams (see SI 13.2)

1.9 For the purposes of rule 32.2(c), the center spans of the Jamestown Verrazano Bridge and the Newport Jamestown Bridge shall be considered gates.

## **APPENDIX 5 – SHIELDS CLASS**

### **1 COURSES**

- 1.1 The course for the Shields Class will be Windward/Leeward with four legs (Start – W – L – W – Finish). All marks shall be rounded to port. No course flag will be displayed on the Race Committee boat.
- 1.2 There will not be an offset mark.
- 1.3 The leeward mark will be the same mark as the starting/finishing mark.

### **2 CLASSES AND IDENTIFICATION**

- 2.1 The Shields Class will be designated as the WHITE Fleet. It is the intention to race in the area between Rose Island and Goat Island. This will be announced at 0900 during the morning announcements.
- 2.2 The VHF channel for the WHITE Fleet is VHF 77.
- 2.3 Each yacht shall display the sponsor flag provided from her backstay. No class numeral pennant is required to be flown for the Shields Class.

### **3 SCHEDULE OF RACES**

Up to four races will be run.

### **4 MARKS**

Marks will be cylindrical ORANGE inflatable buoys.

### **5 THE START**

- 5.1 Races will be started in accordance with rule 26.
- 5.2 Multiple ‘attention’ signals will be made approximately one minute before the warning signal.
- 5.3 The ‘class flag’ flown at the warning signal will be numeral pennant ‘1’.

### **6 COURSE CHANGE**

To maintain a course configuration or change course length marks may be moved as necessary, but no mark shall be moved when any boat is on the leg that it terminates. The Race Committee will attempt to announce any course change on their respective fleet VHF channel 77. This changes RRS 33. Failure to make such an announcement shall not be grounds for redress. This changes rule 62.1(a).

### **7 TIME LIMIT**

The time limit for the first yacht to sail the course and finish is 90 minutes.

### **8 PENALTY SYSTEM**

After starting, a boat that may have broken a rule of Part 2 while racing may take a penalty by taking one turn including one tack and one gybe that, in all other respects, complies with RRS 44.2. *However, if a boat breaks a rule of Part 2 within the two-length zone of any rounding or passing marks, her penalty shall be a Two-Turns Penalty in compliance with RRS 44.2.* This modifies Rule 44.2